

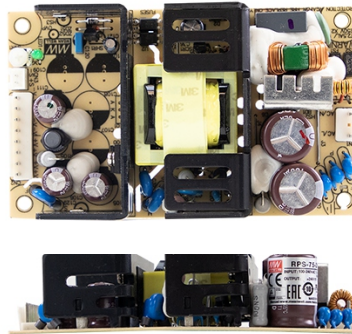

75W Reliable Green Medical Power Supply

RPS-75 series



■ Features

- 5"×3" compact size
- Medical safety approved (2 x MOPP) according to ANSI/AAMI ES60601-1 and IEC/BS EN/EN60601-1
- Suitable for BF application with appropriate system consideration
- 75W convection, 100W force air
- EMI Class B for Class I configuration
- No load power consumption < 0.75W
- Remote sense function
- Protections: Short circuit / Overload / Over voltage
- Lifetime > 80K hours
- Operating altitude up to 3000 meters
- 3 years warranty

■ Description

RPS-75 is a 75W highly reliable green PCB type medical power supply with a high power density on the 5" by 3" footprint. It accepts 90~264VAC input and offers various output voltages between 3.3V and 48V. The working efficiency is up to 86% and the extremely low no load power consumption is down below 0.75W. RPS-75 is able to be used for Class I (with FG) system design. The extremely low leakage current is less than 150 μ A. In addition, it conforms to international medical regulations (2*MOPP) and EMC BS EN/EN55011, perfectly fitting all kinds of BF rated "patient contact" medical system equipment.

■ Applications

- Oral irrigator
- Hemodialysis machine
- Medical computer monitors
- Sleep apnea devices

■ GTIN CODE

MW Search: <https://www.meanwell.com/serviceGTIN.aspx>

■ Model Encoding

RPS - 75 - 3.3

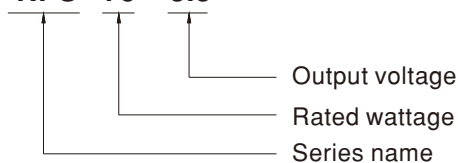

File Name:RPS-75-SPEC 2022-03-18



75W Reliable Green Medical Power Supply

RPS-75 series

SPECIFICATION

MODEL	RPS-75-3.3	RPS-75-5	RPS-75-12	RPS-75-15	RPS-75-24	RPS-75-36	RPS-75-48		
OUTPUT	DC VOLTAGE	3.3V	5V	12V	15V	24V	36V	48V	
	RATED CURRENT	15A	14A	6.3A	5A	3.2A	2.1A	1.6A	
	CURRENT RANGE	0 ~ 20A	0 ~ 18.7A	0 ~ 8.3A	0 ~ 6.7A	0 ~ 4.2A	0 ~ 2.8A	0 ~ 2.1A	
	RATED POWER	49.5W	70W	75.6W	75W	76.8W	75.6W	76.8W	
	PEAK LOAD (23.5CFM)	66W	93.5W	99.6W	100.5W	100.8W	100.8W	100.8W	
	RIPPLE & NOISE (max.) Note.2	60mVp-p	60mVp-p	60mVp-p	60mVp-p	100mVp-p	100mVp-p	100mVp-p	
	VOLTAGE ADJ. RANGE	2.9 ~ 3.6V	4.75 ~ 5.5V	11.4 ~ 13.2V	13.5 ~ 16.5V	22.8 ~ 27.6V	34.2 ~ 39.6V	45.6 ~ 52.8V	
	VOLTAGE TOLERANCE Note.3	±2.0%	±2.0%	±1.0%	±1.0%	±1.0%	±1.0%	±1.0%	
	LINE REGULATION	±0.5%	±0.5%	±0.5%	±0.5%	±0.5%	±0.5%	±0.5%	
	LOAD REGULATION	±1.5%	±1.5%	±1.0%	±1.0%	±1.0%	±1.0%	±1.0%	
SETUP, RISE TIME	500ms, 30ms/230VAC 500ms, 30ms/115VAC at full load								
HOLD UP TIME (Typ.)	90ms/230VAC 20ms/115VAC at full load								
INPUT	VOLTAGE RANGE	90 ~ 264VAC 127 ~ 370VDC							
	FREQUENCY RANGE	47 ~ 63Hz							
	EFFICIENCY(Typ.)	73%	78%	82%	83%	85%	86%	86%	
	AC CURRENT (Typ.)	1.5A/115VAC 1A/230VAC							
	INRUSH CURRENT (Typ.)	COLD START 25A/115VAC 50A/230VAC							
	LEAKAGE CURRENT(max.) Note.4	Earth leakage current < 150 μA/264VAC , Touch current < 100 μA/264VAC							
PROTECTION	OVERLOAD	140 ~ 180% rated output power Protection type : Hiccup mode, recovers automatically after fault condition is removed.							
	OVER VOLTAGE	3.8 ~ 4.5V	5.7 ~ 6.8V	13.8 ~ 16.2V	17.2 ~ 20.3V	27.6 ~ 32.4V	41.4 ~ 48.6V	55.2 ~ 64.8V	
ENVIRONMENT	WORKING TEMP.	-20 ~ +70°C (Refer to "Derating Curve")							
	WORKING HUMIDITY	20 ~ 90% RH non-condensing							
	STORAGE TEMP., HUMIDITY	-40 ~ +85°C, 10 ~ 95% RH non-condensing							
	TEMP. COEFFICIENT	±0.03%/°C (0 ~ 50°C)							
	VIBRATION	10 ~ 500Hz, 2G 10min./1cycle, period for 60min. each along X, Y, Z axes							
	OPERATING ALTITUDE Note.5	3000 meters							
SAFETY & EMC (Note 7)	SAFETY STANDARDS	IEC60601-1, TUV BS EN/EN60601-1, EAC TP TC 004,UL ANSI /AAMI ES60601-1, CAN/CSA-C22.2 No. 60601-1:14 - Edition 3 approved; Design refer to BS EN/EN60335-1							
	ISOLATION LEVEL	Primary-Secondary:2xMOPP, Primary-Earth:1xMOPP							
	WITHSTAND VOLTAGE	I/P-O/P:4KVAC I/P-FG:2KVAC O/P-FG:1.5KVAC							
	ISOLATION RESISTANCE	I/P-O/P, I/P-FG, O/P-FG:100M Ohms / 500VDC / 25°C / 70% RH							
	EMC EMISSION	Parameter	Standard				Test Level / Note		
		Conducted emission	BS EN/EN55011 (CISPR11)				Class B		
		Radiated emission	BS EN/EN55011 (CISPR11)				Class B		
		Harmonic current	BS EN/EN61000-3-2				Class A		
		Voltage flicker	BS EN/EN61000-3-3				-----		
	EMC IMMUNITY	BS EN/EN60601-1-2							
		Parameter	Standard				Test Level / Note		
		ESD	BS EN/EN61000-4-2				Level 4, 15KV air ; Level 4, 8KV contact		
		RF field susceptibility	BS EN/EN61000-4-3				Level 3, 10V/m(80MHz~2.7GHz) Table 9, 9~28V/m(385MHz~5.78GHz)		
		EFT bursts	BS EN/EN61000-4-4				Level 3, 2KV		
Surge susceptibility		BS EN/EN61000-4-5				Level 4, 4KV/Line-FG; 2KV/Line-Line			
Conducted susceptibility		BS EN/EN61000-4-6				Level 3, 10V			
Magnetic field immunity		BS EN/EN61000-4-8				Level 4, 30A/m			
Voltage dip, interruption	BS EN/EN61000-4-11				100% dip 1 periods, 30% dip 25 periods, 100% interruptions 250 periods				
OTHERS	MTBF	2837.6K hrs min. Telcordia SR-332 (Bellcore) ; 446.8K hrs min. MIL-HDBK-217F (25°C)							
	DIMENSION (L*W*H)	127*76.2*31mm or 5" * 3" * 1.22" inch							
	PACKING	0.26Kg; 63pcs/16.3Kg/1.28CUFT							
NOTE	<p>1. All parameters NOT specially mentioned are measured at 230VAC input, rated load and 25°C of ambient temperature.</p> <p>2. Ripple & noise are measured at 20MHz of bandwidth by using a 12" twisted pair-wire terminated with a 0.1μf & 47μf parallel capacitor.</p> <p>3. Tolerance : includes set up tolerance, line regulation and load regulation.</p> <p>4. Touch current was measured from primary input to DC output.</p> <p>5. The ambient temperature derating of 3.5°C/1000m with fanless models and of 5°C/1000m with fan models for operating altitude higher than 2000m(6500ft).</p> <p>6. Heat Sink HS1,HS2,HS3 can not be shorted.</p> <p>7. The power supply is considered a component which will be installed into a final equipment. All the EMC tests are been executed by mounting the unit on a 360mm*360mm metal plate with 1mm of thickness. The final equipment must be re-confirmed that it still meets EMC directives. For guidance on how to perform these EMC tests, please refer to "EMI testing of component power supplies." (as available on http://www.meanwell.com)</p> <p>※ Product Liability Disclaimer : For detailed information, please refer to https://www.meanwell.com/serviceDisclaimer.aspx</p>								

File Name:RPS-75-SPEC 2022-03-18



75W Reliable Green Medical Power Supply

RPS-75 series

Block Diagram

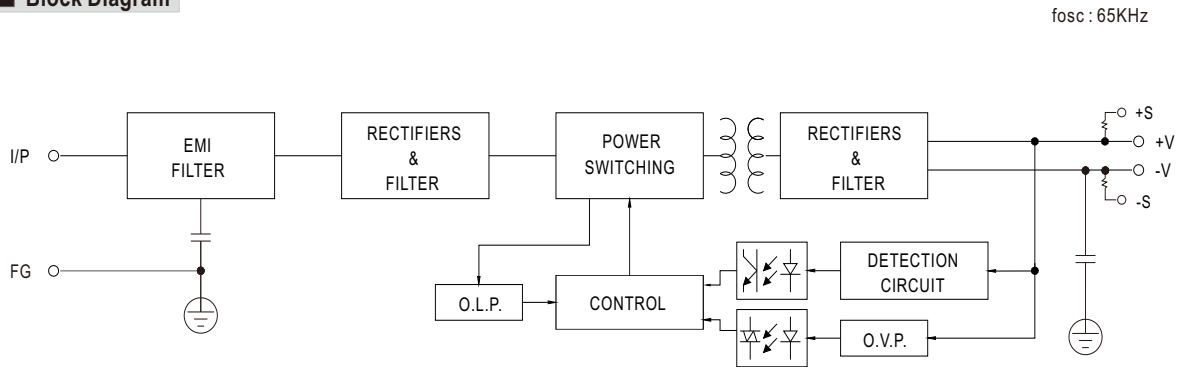

Derating Curve

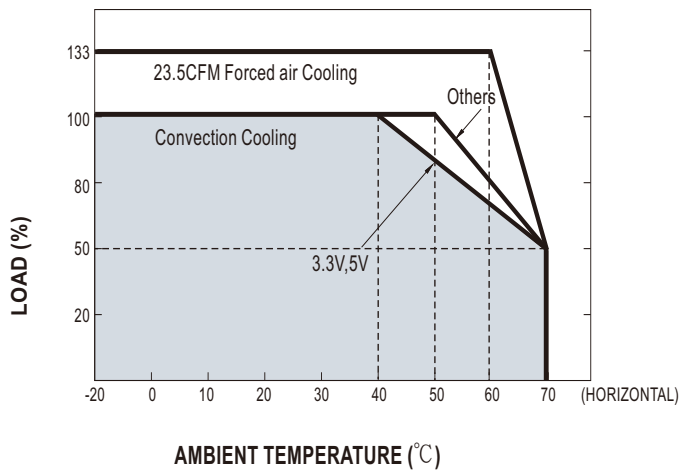

Output Derating VS Input Voltage

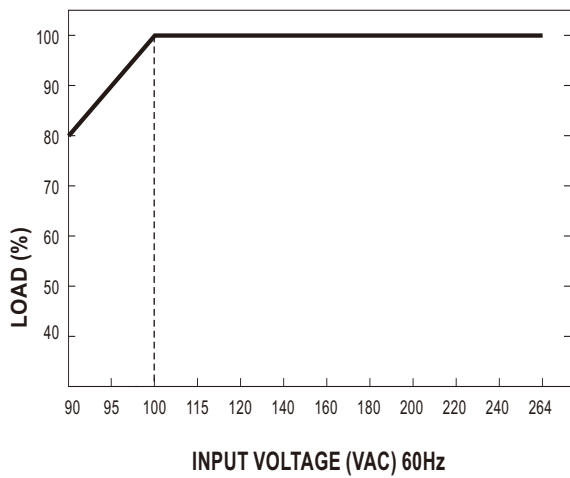

File Name:RPS-75-SPEC 2022-03-18



75W Reliable Green Medical Power Supply

RPS-75 series

Mechanical Specification

Unit:mm

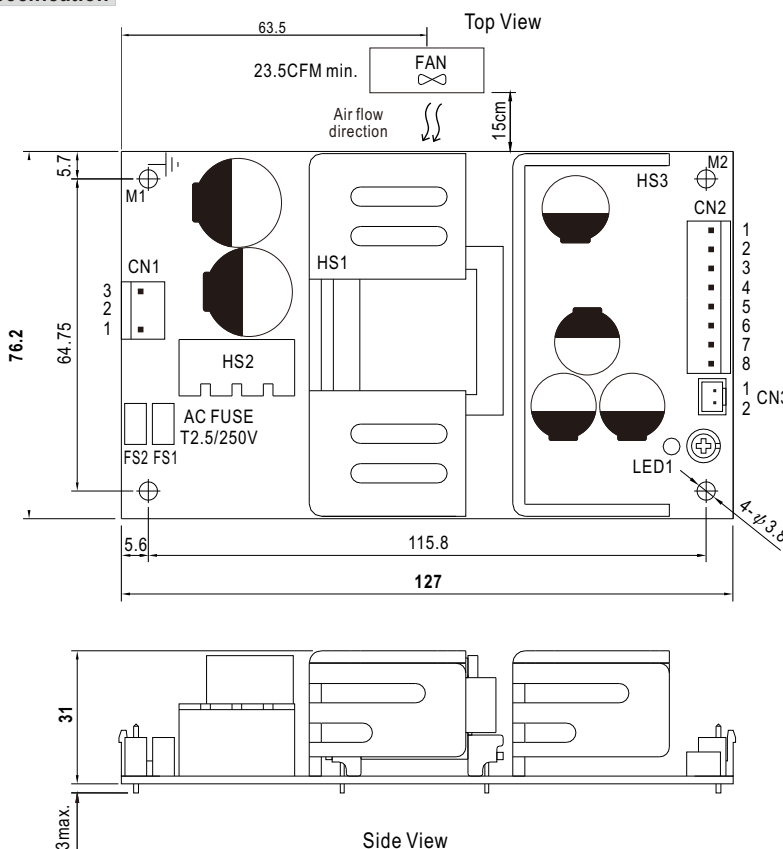

AC Input Connector (CN1) : JST B3P-VH or equivalent

Pin No.	Assignment	Mating Housing	Terminal
1	AC/N	JST VHR or equivalent	JST SVH-21T-P1.1 or equivalent
2	No Pin		
3	AC/L		

Remote Sense(CN3) : JST B2B-XH or equivalent

Pin No.	Assignment	Mating Housing	Terminal
1	RS+	JST XHP or equivalent	JST SXH-001T-P0.6 or equivalent
2	RS-		

DC Output Connector (CN2) : JST B8P-VH or equivalent

Pin No.	Assignment	Mating Housing	Terminal
1,2,3,4	+V	JST VHR or equivalent	JST SVH-21T-P1.1 or equivalent
5,6,7,8	-V		

⊕ : Grounding Required

- ⚠ 1.HS1,HS2,HS3 cannot be shorted.
- 2.M1 is safety ground. For better EMC performance,Please secure an electrical connection between M1,M2 and chassis grounding.

Installation Manual

Please refer to : <http://www.meanwell.com/manual.html>

We are here for you. Addresses and Contacts.

Headquarter Switzerland:

Angst+Pfister Sensors and Power AG
Thurgauerstrasse 66
CH-8050 Zurich
Phone +41 44 877 35 00
sensorsandpower@angst-pfister.com

Office Germany:

Angst+Pfister Sensors and Power Deutschland GmbH
Edisonstraße 16
D-85716 Unterschleißheim
Phone +49 89 374 288 87 00
sensorsandpower.de@angst-pfister.com

Scan here and get an overview of personal contacts!



sensorsandpower.angst-pfister.com
