



10W High Reliable Green Medical Encapsulated Type

MPM-10 series

User's Manual



ANSI/AAMI ES60601-1 BS EN/EN60601-1 IEC60601-1 TPTC004



■ Features

- 1.8"x1" compact size
- Medical safety approved (2 x MOPP) according to ANSI/AAMI ES60601-1 and IEC/BS EN/EN60601-1
- Suitable for BF application with appropriate system consideration
- No load power consumption < 0.075W
- Extremely low leakage current
- Wide operating temp. range -30 ~ +85°C
- EMI class B for class II configuration
- Protections:
Short circuit / Overload / Over voltage / Over temperature
- No minimum load required
- 3 years warranty

■ Applications

- Portable medical device
- Mobile clinical workstation
- Medical computer monitor
- Medical examination instrument

■ GTIN CODE

MW Search: <https://www.meanwell.com/serviceGTIN.aspx>

■ Description

MPM-10 is a 10W high density and small size (45.7*25.4*21.5mm) AC/DC module type medical grade power supply series offered in pin type. It features the operation for 80~264VAC, a low no load power consumption less than 0.075W, a high efficiency up to 84%, Class II (no FG) double insulation, outstanding dissipation and high lifespan thanks to the interior potting, 5G anti-vibration, high EMC performance, 4KVAC isolation, etc. The design observes IEC/BS EN/EN60601-1 and ANSI/AAMI ES60601-1 version three with 2xMOPP level and ultra-low leakage current (<80 μA). It is very suitable for BF (patient contact) type medical device or relevant equipment.

■ Model Encoding

MPM - 10 - 5

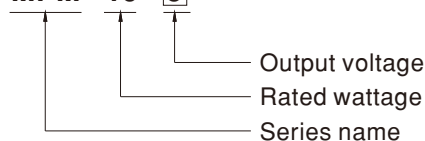

File Name: MPM-10-SPEC 2022-03-18



10W High Reliable Green Medical Encapsulated Type

MPM-10 series**SPECIFICATION**

MODEL		MPM-10-3.3	MPM-10-5	MPM-10-12	MPM-10-15	MPM-10-24	
OUTPUT	DC VOLTAGE	3.3V	5V	12V	15V	24V	
	RATED CURRENT	2.5A	2A	0.85A	0.67A	0.42A	
	CURRENT RANGE <small>Note.2</small>	0 ~ 2.5A	0 ~ 2A	0 ~ 0.85A	0 ~ 0.67A	0 ~ 0.42A	
	PEAK CURRENT	2.75A	2.2A	0.94A	0.74A	0.46A	
	RATED POWER	8.3W	10W	10.2W	10W	10W	
	PEAK LOAD(10sec.) <small>Note.3</small>	9W	11W	11.3W	11.1W	11W	
	RIPPLE & NOISE (max.) <small>Note.4</small>	120mVp-p	100mVp-p	180mVp-p	180mVp-p	200mVp-p	
	VOLTAGE TOLERANCE <small>Note.5</small>	±2.5%	±2.5%	±2.5%	±2.5%	±2.5%	
	LINE REGULATION	±0.3%	±0.3%	±0.3%	±0.3%	±0.3%	
	LOAD REGULATION	±0.5%	±0.5%	±0.5%	±0.5%	±0.5%	
SETUP, RISE TIME	1000ms, 30ms/230VAC 1000ms, 30ms/115VAC at full load						
HOLD UP TIME (Typ.)	40ms/230VAC 8ms/115VAC at full load						
INPUT	VOLTAGE RANGE <small>Note.6</small>	80 ~ 264VAC					
	FREQUENCY RANGE	47 ~ 440Hz					
	EFFICIENCY (Typ.)	78%	81%	83%	83%	84%	
	AC CURRENT (Typ.)	0.3A/115VAC 0.2A/230VAC					
	INRUSH CURRENT (Typ.)	COLD START 25A/115VAC 45A/230VAC					
	LEAKAGE CURRENT (max.) <small>Note.7</small>	Touch current <80 μ A/264VAC					
PROTECTION	OVERLOAD	110% ~ 180% rated output power Protection type : Hiccup mode, recovers automatically after fault condition is removed					
	OVER VOLTAGE	3.8 ~ 5V	5.8 ~ 6.8V	13.8 ~ 16.2V	17.3 ~ 20.3V	27.6 ~ 32.4V	
	OVER TEMPERATURE	Protection type : Shut down o/p voltage, recovers automatically after temperature goes down					
ENVIRONMENT	WORKING TEMP.	-30 ~ +85 $^{\circ}$ C (Refer to "Derating Curve")					
	WORKING HUMIDITY	20 ~ 90% RH non-condensing					
	STORAGE TEMP., HUMIDITY	-40 ~ +100 $^{\circ}$ C, 10 ~ 95% RH non-condensing					
	TEMP. COEFFICIENT	±0.03%/ $^{\circ}$ C (0 ~ 60 $^{\circ}$ C)					
	SOLDERING TEMPERATURE	260 $^{\circ}$ C ±5 $^{\circ}$ C/10sec.max.					
	VIBRATION	10 ~ 500Hz, 5G 10min./1cycle, period for 60min. each along X, Y, Z axes					
	LEAD TEMPERATURE	260±5 $^{\circ}$ C, 5s (max.)					
	OPERATING ALTITUDE <small>Note.8</small>	5000 meters					
SAFETY & EMC (Note 9)	SAFETY STANDARDS	IEC60601-1, BS EN/EN60601-1, EAC TP TC 004, UL ANSI/AAMI ES60601-1(3.1 version), CAN/CSA-C22 3 rd Edition approved ; Design refer to BS EN/EN60335-1(by request)					
	ISOLATION LEVEL	Primary-Secondary: 2xMOPP					
	WITHSTAND VOLTAGE	I/P-O/P:4KVAC					
	ISOLATION RESISTANCE	I/P-O/P:100M Ohms / 500VDC / 25 $^{\circ}$ C / 70% RH					
	EMC EMISSION	Parameter	Standard			Test Level / Note	
		Conducted	BS EN/EN55011 (CISPR11)			Class B	
		Radiated	BS EN/EN55011 (CISPR11)			Class B	
		Harmonic Current	BS EN/EN61000-3-2			Class A	
		Voltage Flicker	BS EN/EN61000-3-3			-----	
	EMC IMMUNITY	Parameter	Standard			Test Level / Note	
		ESD	BS EN/EN61000-4-2			Level 4, 15KV air ; Level 4, 8KV contact	
		RF field susceptibility	BS EN/EN61000-4-3			Level 3, 10V/m (80MHz~2.7GHz) Table 9, 9~28V/m(385MHz~5.78GHz)	
		EFT bursts	BS EN/EN61000-4-4			Level 3, 2KV	
		Surge susceptibility	BS EN/EN61000-4-5			Level 3, 1KV/Line-Line	
		Conducted susceptibility	BS EN/EN61000-4-6			Level 3, 10V	
Magnetic field immunity		BS EN/EN61000-4-8			Level 4, 30A/m		
Voltage dip, interruption		BS EN/EN61000-4-11			100% dip 1 periods, 30% dip 25 periods, 100% interruptions 250 periods		
OTHERS	MTBF	9314.1K hrs min. Telcordia SR-332 (Bellcore) ; 1756.2K hrs min. MIL-HDBK-217F (25 $^{\circ}$ C)					
	DIMENSION	45.7*25.4*21.5mm (L*W*H) or 1.8*1.0*0.85" inch					
	PACKING	0.035Kg; 270pcs/10.5Kg/0.94CUFT					
NOTE	<p>1. All parameters NOT specially mentioned are measured at 230VAC input, rated load and 25$^{\circ}$C of ambient temperature.</p> <p>2. No minimum load required.</p> <p>3. 33% Duty cycle maximum within every 30 seconds. Average output power should not exceed the rated power</p> <p>4. Ripple & noise are measured at 20MHz of bandwidth by using a 12" twisted pair-wire terminated with a 0.1μf & 47μf parallel capacitor.</p> <p>5. Tolerance : includes set up tolerance, line regulation and load regulation.</p> <p>6. Derating may be needed under low input voltages. Please check the derating curve for more details.</p> <p>7. Touch current was measured from primary input to DC output.</p> <p>8. The ambient temperature derating of 3.5$^{\circ}$C/1000m with fanless models and of 5$^{\circ}$C/1000m with fan models for operating altitude higher than 2000m(6500ft).</p> <p>9. The power supply is considered a component which will be installed into a final equipment. The final equipment must be re-confirmed that it still meets EMC directives. For guidance on how to perform these EMC tests, please refer to "EMI testing of component power supplies." (as available on http://www.meanwell.com)</p> <p>※ Product Liability Disclaimer : For detailed information, please refer to https://www.meanwell.com/serviceDisclaimer.aspx</p>						

File Name:MPM-10-SPEC 2022-03-18



10W High Reliable Green Medical Encapsulated Type

MPM-10 series

Block Diagram

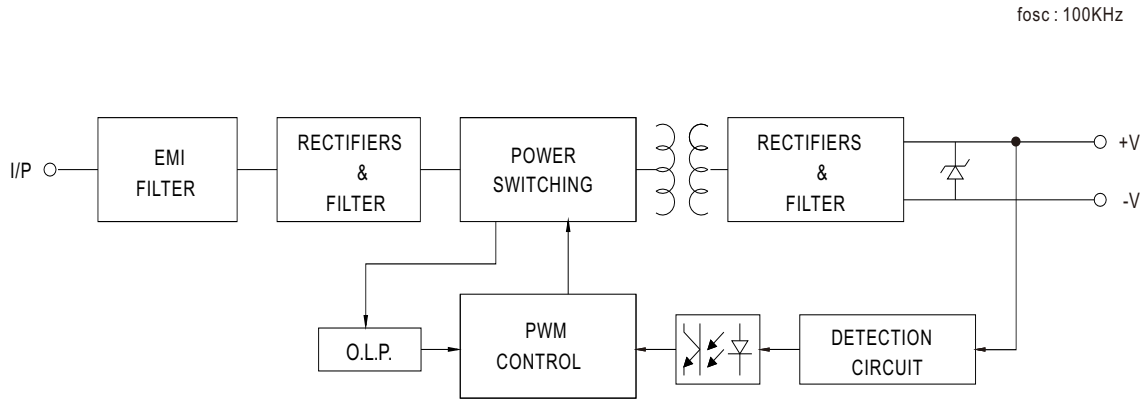

Derating Curve

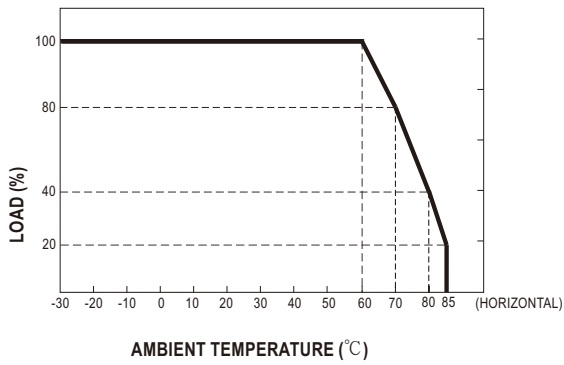

Output Derating VS Input Voltage

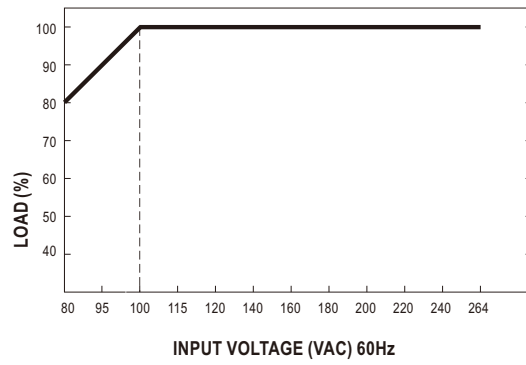

File Name:MPM-10-SPEC 2022-03-18



10W High Reliable Green Medical Encapsulated Type

MPM-10 series

■ Mechanical Specification

Case No.222A Unit:(mm)

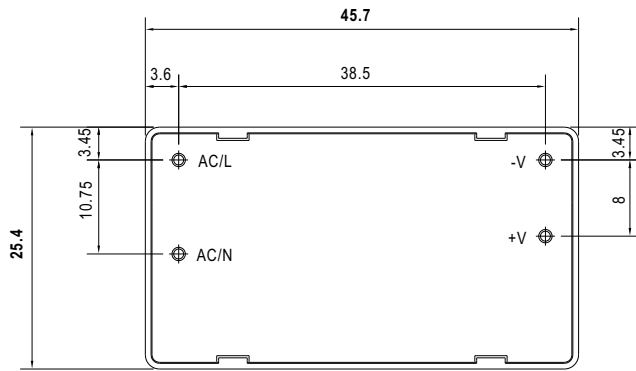

BOTTOM VIEW

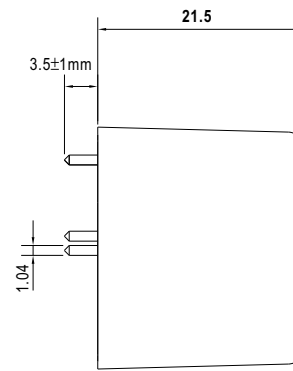

SIDE VIEW

■ Installation Manual

Please refer to : <http://www.meanwell.com/manual.html>

File Name:MPM-10-SPEC 2022-03-18

We are here for you. Addresses and Contacts.

Headquarter Switzerland:

Angst+Pfister Sensors and Power AG
Thurgauerstrasse 66
CH-8050 Zurich
Phone +41 44 877 35 00
sensorsandpower@angst-pfister.com

Office Germany:

Angst+Pfister Sensors and Power Deutschland GmbH
Edisonstraße 16
D-85716 Unterschleißheim
Phone +49 89 374 288 87 00
sensorsandpower.de@angst-pfister.com

Scan here and get an overview of personal contacts!



sensorsandpower.angst-pfister.com
