



40W Single Output Switching Power Supply

DRA-40 series



User's Manual



■ Features

- Universal AC input / Full range
- Protections: Short circuit / Overload / Over voltage
- Can be installed on DIN rail TS-35/7.5 or 15
- Output Voltage adjustable through internal potentiometer
- Output Current adjustable through external 1~10Vdc, PWM signal or resistance
- Cooling by free air convection
- Pass LPS
- LED indicator for power on
- 100% full load burn-in test
- 3 years warranty

■ Applications

- Machine vision inspection system
- Plant cultivation system

■ GTIN CODE

MW Search: <https://www.meanwell.com/serviceGTIN.aspx>

■ Description

DRA-40 is one 40W AC/DC DIN rail power supply, featuring the adjustable output current. Users are able to easily change the constant output current level, via 1~10Vdc, PWM signal or resistance. DRA-40 can be mounted on DIN rail TS-35/7.5 or 15; in addition, the width of the unit is only 40mm that it is well suited for the installation in a limited spacing. DRA-40 accepts the universal AC input between 90VAC and 264VAC; the efficiency is up to 87% that the entire series can operate, under free air convection, from -30°C through 70°C.

■ Model Encoding

DRA - 40 - 12

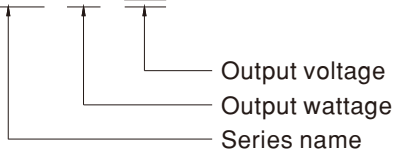

File Name:DRA-40-SPEC 2022-03-18



40W Single Output Switching Power Supply

DRA-40 series

SPECIFICATION

MODEL		DRA-40-12	DRA-40-24
OUTPUT	DC VOLTAGE	12V	24V
	CONSTANT CURRENT REGION	3~12V	3~24V
	RATED CURRENT	3.34A	1.7A
	CURRENT RANGE	0 ~ 3.34A	0 ~ 1.7A
	RATED POWER	40.08W	40.8W
	RIPPLE & NOISE (max.) Note.2	120mVp-p	150mVp-p
	VOLTAGE ADJ. RANGE	12 ~ 15V	24 ~ 30V
	VOLTAGE TOLERANCE Note.3	±1.0%	±1.0%
	LINE REGULATION	±0.5%	±0.5%
	LOAD REGULATION	±0.5%	±0.5%
SETUP, RISE TIME Note.4	400ms, 90ms/230VAC 800ms, 90ms/115VAC at full load		
HOLD UP TIME (Typ.)	50ms/230VAC 10ms/115VAC at full load		
INPUT	VOLTAGE RANGE	90 ~ 264VAC 127 ~ 370VDC [DC input operation possible by connecting AC/L(+), AC/N(-)]	
	FREQUENCY RANGE	47 ~ 63Hz	
	EFFICIENCY (Typ.)	85%	87%
	AC CURRENT (Typ.)	0.8A/115VAC 0.6A/230VAC	
	INRUSH CURRENT (Typ.)	COLD START 30A/115VAC 60A/230VAC	
PROTECTION	OVERLOAD	95 ~ 108% rated output power Protection type : Constant current limiting, recovers automatically after fault condition is removed	
	OVER VOLTAGE	14.49 ~ 18.63V	28.98 ~ 37.26V Protection type : Shut down o/p voltage, re-power on to recover
ENVIRONMENT	WORKING TEMP.	-30 ~ +70°C (Refer to "Derating Curve")	
	WORKING HUMIDITY	20 ~ 90% RH non-condensing	
	STORAGE TEMP., HUMIDITY	-40 ~ +85°C, 10 ~ 95% RH	
	TEMP. COEFFICIENT	±0.03%/°C (0 ~ 55°C) on output	
	VIBRATION	10 ~ 500Hz, 2G 10min./1cycle, 60min. each along X, Y, Z axes	
SAFETY & EMC (Note 5)	SAFETY STANDARDS	UL62368-1, TUV BS EN/EN62368-1, EAC TP TC 004 approved	
	WITHSTAND VOLTAGE	I/P-O/P:3KVAC I/P-FG:2KVAC O/P-FG:0.5KVAC	
	ISOLATION RESISTANCE	I/P-O/P, I/P-FG, O/P-FG:100M Ohms / 500VDC / 25°C / 70% RH	
	EMC EMISSION	Compliance to BS EN/EN55032 (CISPR32) Class B, BS EN/EN61000-3-2,-3, EAC TP TC 020	
OTHERS	MTBF	2940.7K hrs min. Telcordia SR-332 (Bellcore) ; 439.3K hrs min. MIL-HDBK-217F (25°C)	
	DIMENSION	40*90*100mm (W*H*D)	
	PACKING	0.3Kg; 42pcs/13.6Kg/0.82CUFT	
NOTE	<p>1. All parameters NOT specially mentioned are measured at 230VAC input, rated load and 25°C of ambient temperature.</p> <p>2. Ripple & noise are measured at 20MHz of bandwidth by using a 12" twisted pair-wire terminated with a 0.1uf & 47uf parallel capacitor.</p> <p>3. Tolerance : includes set up tolerance, line regulation and load regulation.</p> <p>4. Length of set up time is measured at cold first start. Turning ON/OFF the power supply may lead to increase of the set up time.</p> <p>5. The power supply is considered a component which will be installed into a final equipment. The final equipment must be re-confirmed that it still meets EMC directives. For guidance on how to perform these EMC tests, please refer to "EMI testing of component power supplies." (as available on http://www.meanwell.com)</p> <p>6. Installation clearances : 40mm on top, 20mm on the bottom, 5mm on the left and right side are recommended when loaded permanently with full power. In case the adjacent device is a heat source, 15mm clearance is recommended.</p> <p>7. The ambient temperature derating of 3.5°C/1000m with fanless models and of 5°C/1000m with fan models for operating altitude higher than 2000m(6500ft).</p> <p>※ Product Liability Disclaimer : For detailed information, please refer to https://www.meanwell.com/serviceDisclaimer.aspx</p>		

File Name:DRA-40-SPEC 2022-03-18



40W Single Output Switching Power Supply

DRA-40 series

Block Diagram

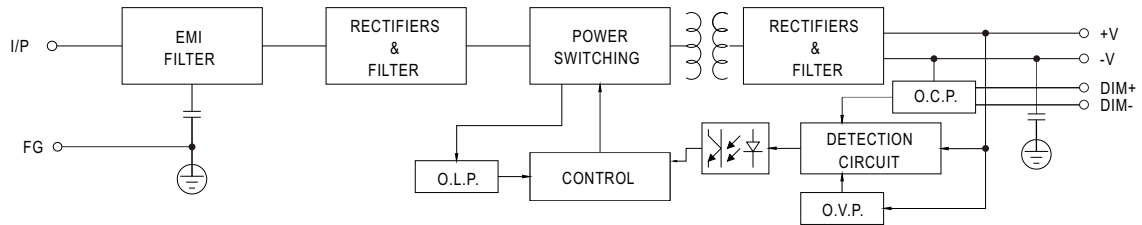

Derating Curve

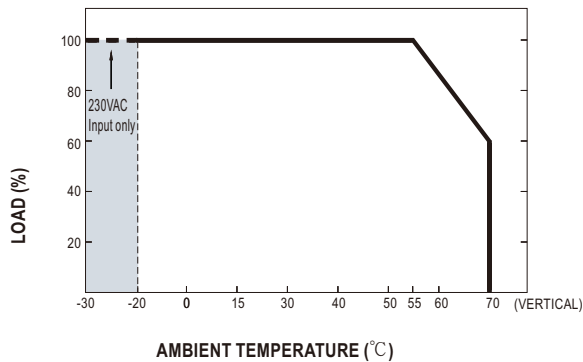

Static Characteristics

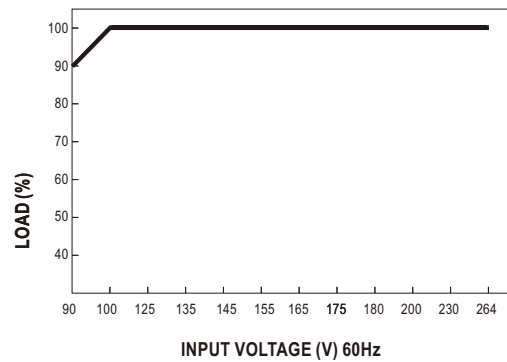

OUTPUT CURRENT ADJUSTMENT OPERATION

- ※ Built-in 3 in 1 current adjustment function . Output constant current level can be adjusted by applying 1 ~ 10Vdc, 10V PWM signal or resistance between DIM+ and DIM-.
- ※ Please DO NOT connect "DIM-" to "-V".
- ※ Reference resistance value for output current adjustment (Typical)

Resistance value	Single Power supply	10KΩ	20KΩ	30KΩ	40KΩ	50KΩ	60KΩ	70KΩ	80KΩ	90KΩ	100KΩ	OPEN
	Multiple Power supplies (N=Power supply quantity for simultaneous current adjustment control)	10KΩ/N	20KΩ/N	30KΩ/N	40KΩ/N	50KΩ/N	60KΩ/N	70KΩ/N	80KΩ/N	90KΩ/N	100KΩ/N	-----
Percentage of rated current		10%	20%	30%	40%	50%	60%	70%	80%	90%	100%	102%~108%

※ 1 ~ 10Vdc for output current adjustment (Typical)

Applied Source	1V	2V	3V	4V	5V	6V	7V	8V	9V	10V	OPEN
Percentage of rated current	10%	20%	30%	40%	50%	60%	70%	80%	90%	100%	102%~108%

※ 10V PWM signal for output current adjustment (Typical): Frequency range :100Hz ~ 3KHz

Duty value	10%	20%	30%	40%	50%	60%	70%	80%	90%	100%	OPEN
Percentage of rated current	10%	20%	30%	40%	50%	60%	70%	80%	90%	100%	102%~108%

File Name:DRA-40-SPEC 2022-03-18



40W Single Output Switching Power Supply

DRA-40 series

※Using the current adjustment function can not adjust the output current to 0A. Please refer to the connection method below to adjust the output current to 0A.

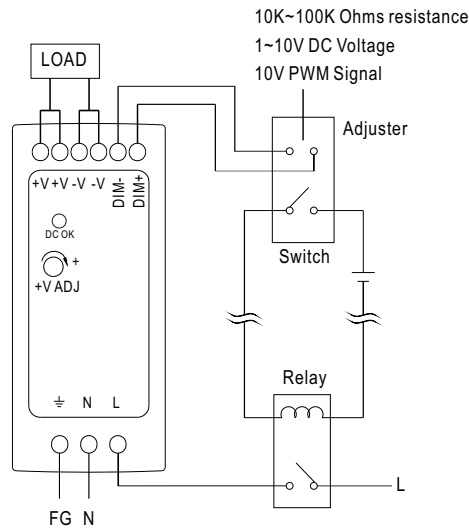

DRIVING METHODS OF APPLICATIONS

The power supply may either work in "constant voltage mode or constant current mode"

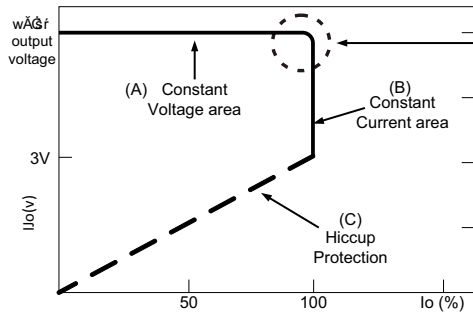

In the constant current region, the highest voltage at the output of the driver depends on the configuration of the end systems. Should there be any compatibility issues, please contact MEAN WELL.

File Name:DRA-40-SPEC 2022-03-18



40W Single Output Switching Power Supply

DRA-40 series

■ Mechanical Specification

Case No.962A Unit:mm

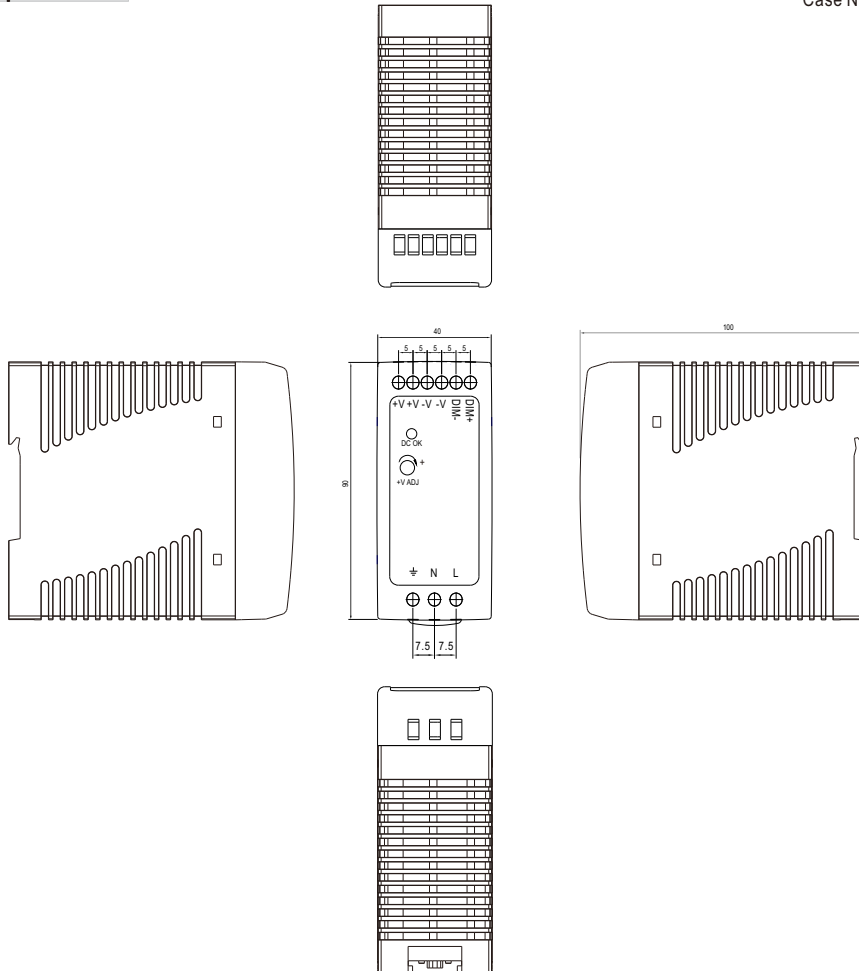

■ Installation Instruction

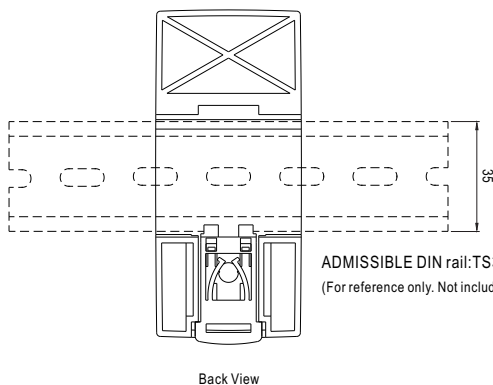

This series fits DIN rail TS35/7.5 or TS35/15.
For installation details, please refer to the Instruction manual.

ADMISSIBLE DIN rail: TS35/7.5 OR TS35/15
(For reference only. Not included with unit.)

■ Installation Manual

Please refer to : <http://www.meanwell.com/manual.html>

We are here for you. Addresses and Contacts.

Headquarter Switzerland:

Angst+Pfister Sensors and Power AG
Thurgauerstrasse 66
CH-8050 Zurich
Phone +41 44 877 35 00
sensorsandpower@angst-pfister.com

Office Germany:

Angst+Pfister Sensors and Power Deutschland GmbH
Edisonstraße 16
D-85716 Unterschleißheim
Phone +49 89 374 288 87 00
sensorsandpower.de@angst-pfister.com

Scan here and get an overview of personal contacts!



sensorsandpower.angst-pfister.com
